



LNH-500 | High Precision, High Speed Horizontal Machining Centers



LNH-500, the only one of main features is environmentally friendly machine, conserve the resources and beauty on earth.

High speed and rigidity of LNH-500 machine, is comparatively light in total machine weight, with up to 20% accelerated feed rate, and the structure of machine body is used the high rigid casting.

Potentially used from low speed in casting processing to high speed in aluminum processing, to meet a wide range of needs in variety, but mainly for automotive industry.



Basic Structure ▶ Rapid travel increased by 20%

Rapid Travel (X/Y/Z)

Prior model HT-500 48m/min → LNH-500 60m/min

Cutting feedrate (X/Y/Z)

Prior model HT-500 10m/min → LNH-500 60m/min

Max. Acceleration (X/Y/Z)

LNH-500 0.63/0.78/0.68G (6.2/7.6/6.7m/s²)

* SIEMENS Controller up to 60 m/min

▶ High-rigidity Bed

X axis and Y axis linear guideway configure high position to achieve high rigid machine body.

Three points support structure

Three points support structure improves the installation of stability.

60 m/min rapid travel of 3 axis is the fastest one among the same level in current industry.

Symmetrical column design greatly reduce the effects of thermal displacement.

With built-in spindle to avoid vibration resulted from high-speed cutting, to ensure processing quality.

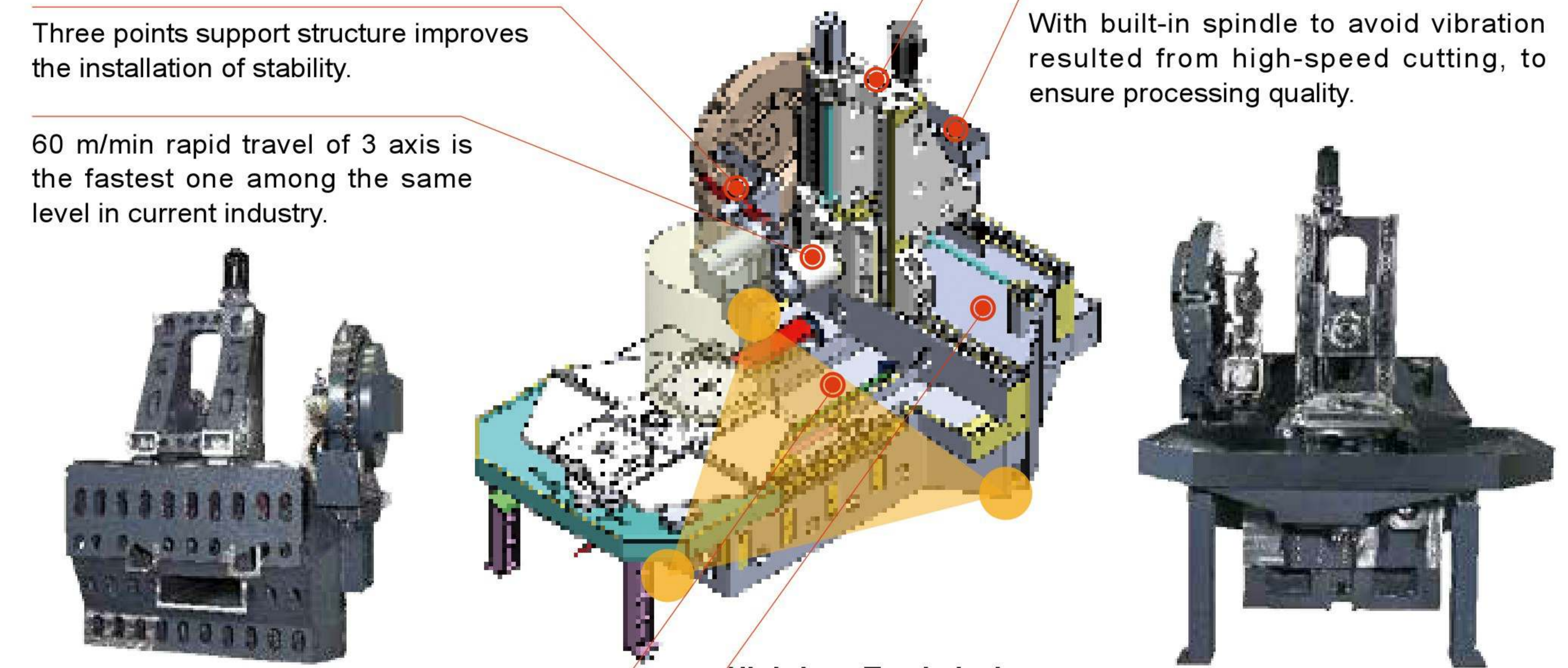

High-Low Track design

The base is designed in high and low rails with lightweight column, which shows the lowest energy consumption and optimal characteristics. The large gap between high and low rail design, not only with the best cutting rigidity, but largely enhance the stability of the base.

Central chip removal system design

The middle of the base designed especially for chip removal system to clear chips efficiently.



▶ A shorter tool can be used

By shorten minimize the distance from spindle nose to the table centre for 84mm, and shorter tool can be used to achieve higher rigidity.

The minimum distance from the spindle nose to table center

Prior model HT-500

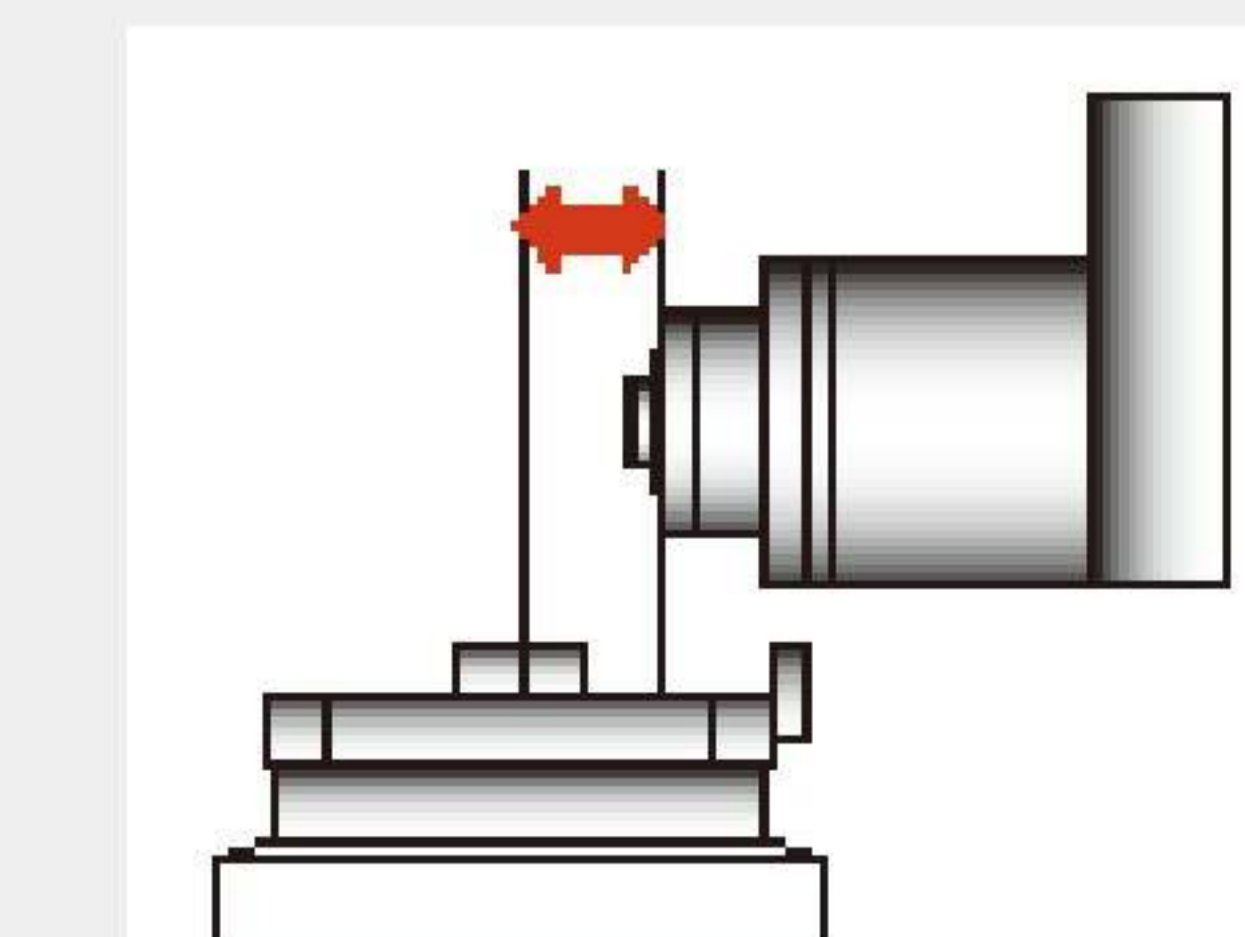

154mm

LNH-500

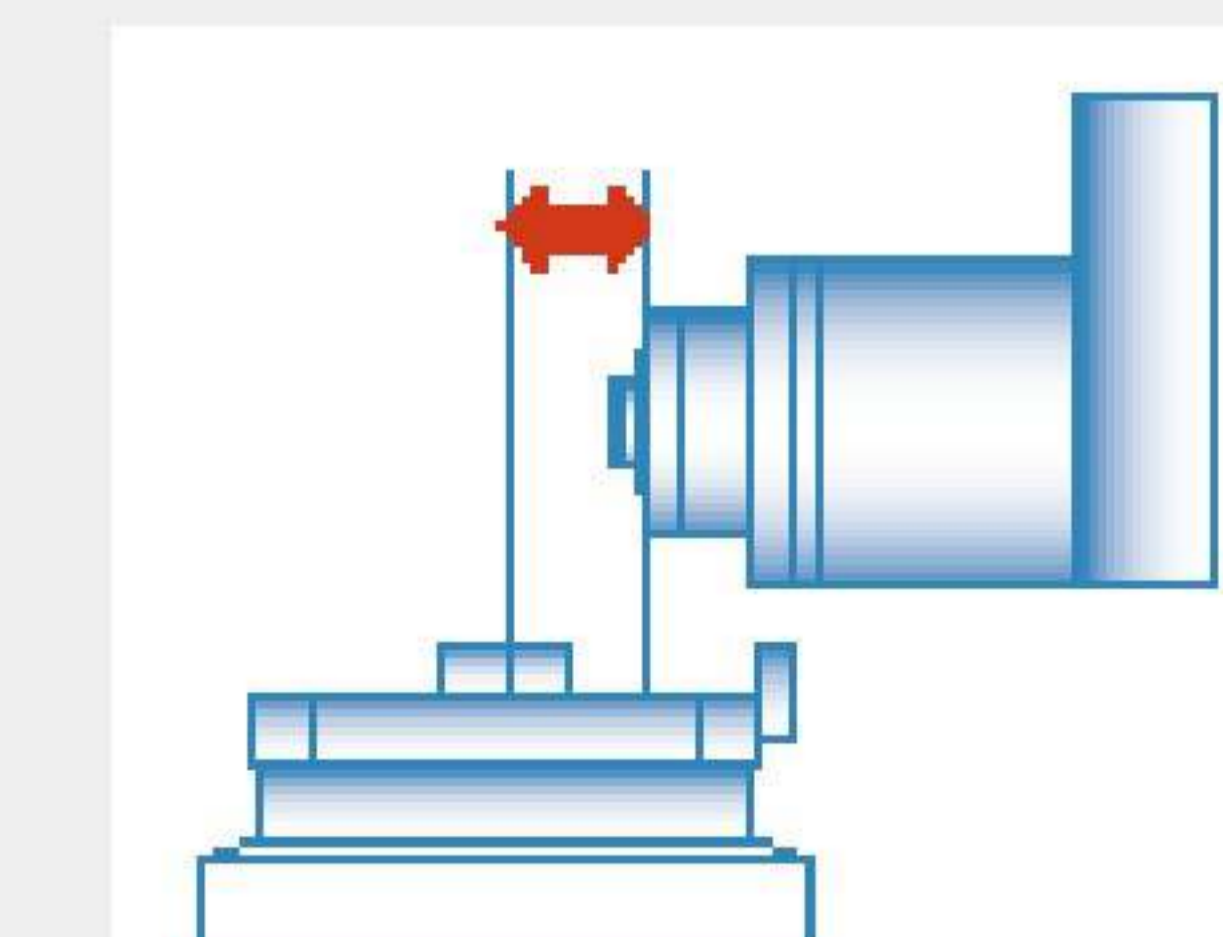

70mm



LNH-500 Traverse (X/Y/Z)

730 / 730 / 880mm

Spindle

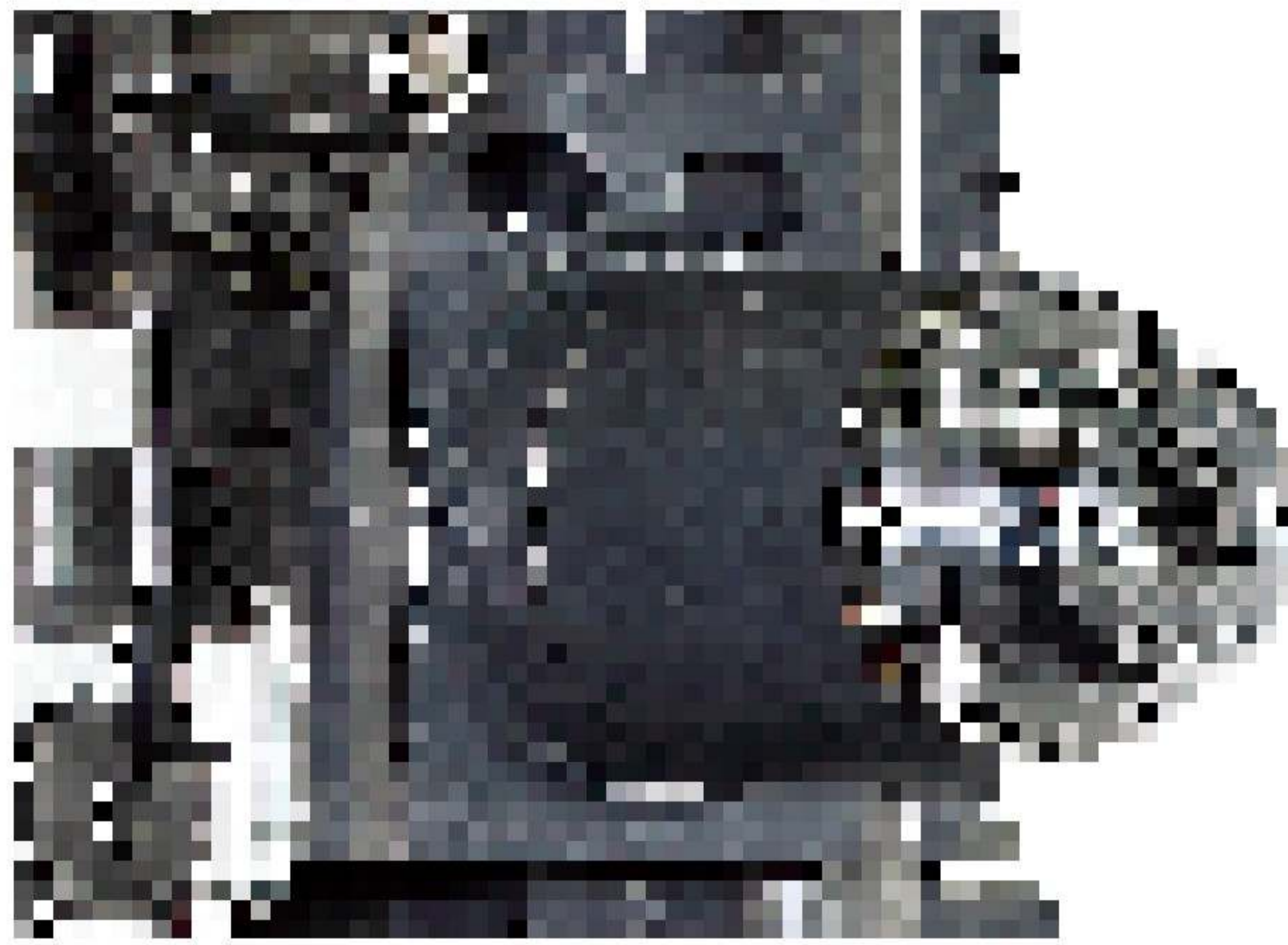

LNH-500	Standard specification
The. max. spindle speed	15,000 min ⁻¹
Spindle power	35/28 kW (S6-40%, TS= 2min/continuous)

▶ Increased the inner diameter of the spindle bearing

The inner diameter of the spindle bearing was increased to improve rigidity. At the same moment spindle motor provides the maximum output of the built-in spindle power.

▶ Symmetric spindle configuration

A spindle cutting fluid connection, a piping of cooling oil and an assembling bolt are assembled due to spindle center in a symmetric spindle configuration. Such feature may help to reduce heat distortion, vibration suppression and keep high rigidity of the structure.

▶ Maze type spindle structure

Maze type spindle structure is used to prevent ingress the cutting fluid into the spindle, such feature improves the durability of the spindle.

Workpiece dimension

Max. workpiece height	Max. workpiece diameter	Max. table capacity
1000mm	Ø800mm	500kgs [<small>OP</small> 600kgs]

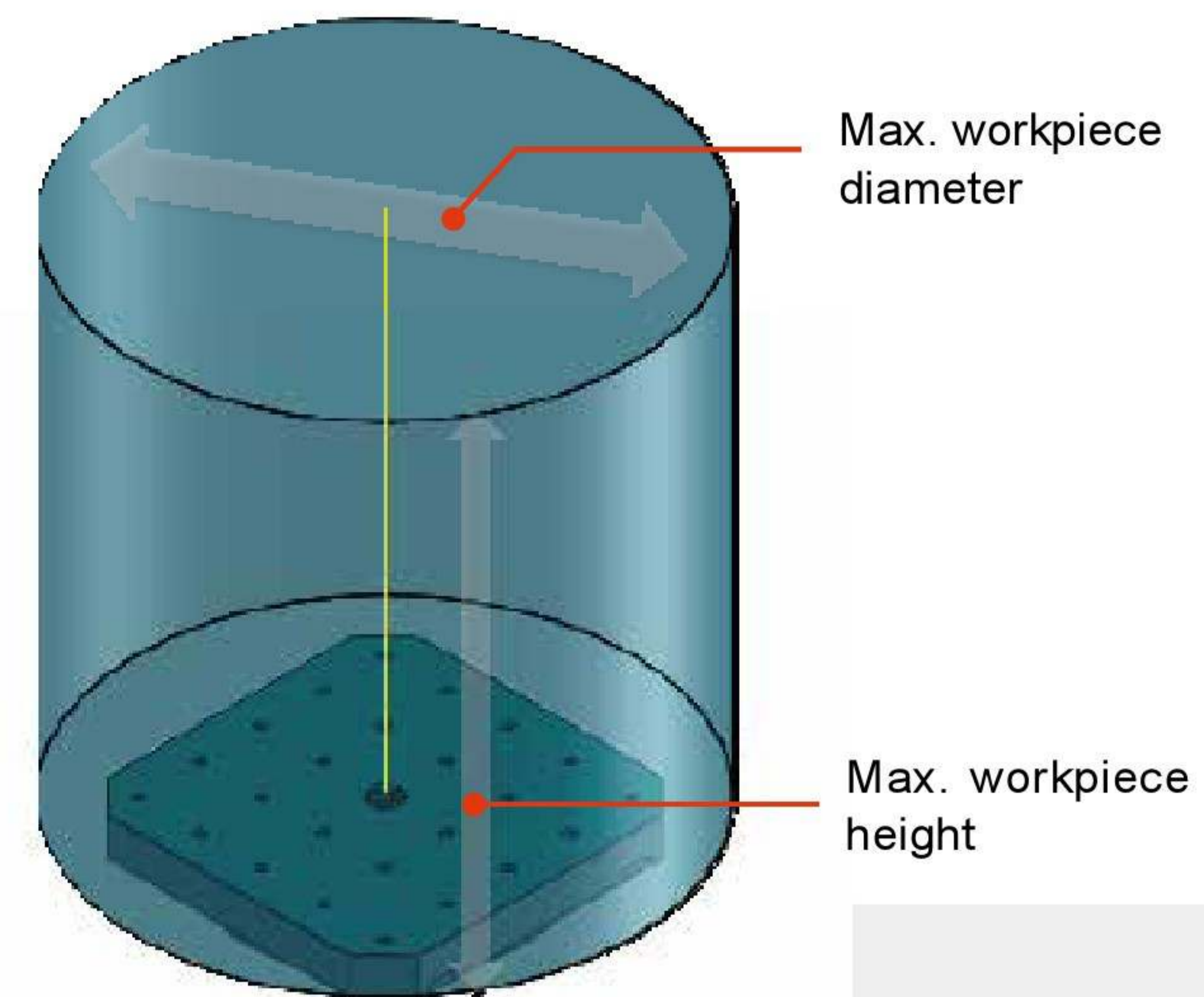

Double-sided constraint configuration

The flexural rigidity of the tool is increased by specifying the end surface slope in addition to the spindle slope. Such feature extends tool life, improves cutting performance and machining accuracy.

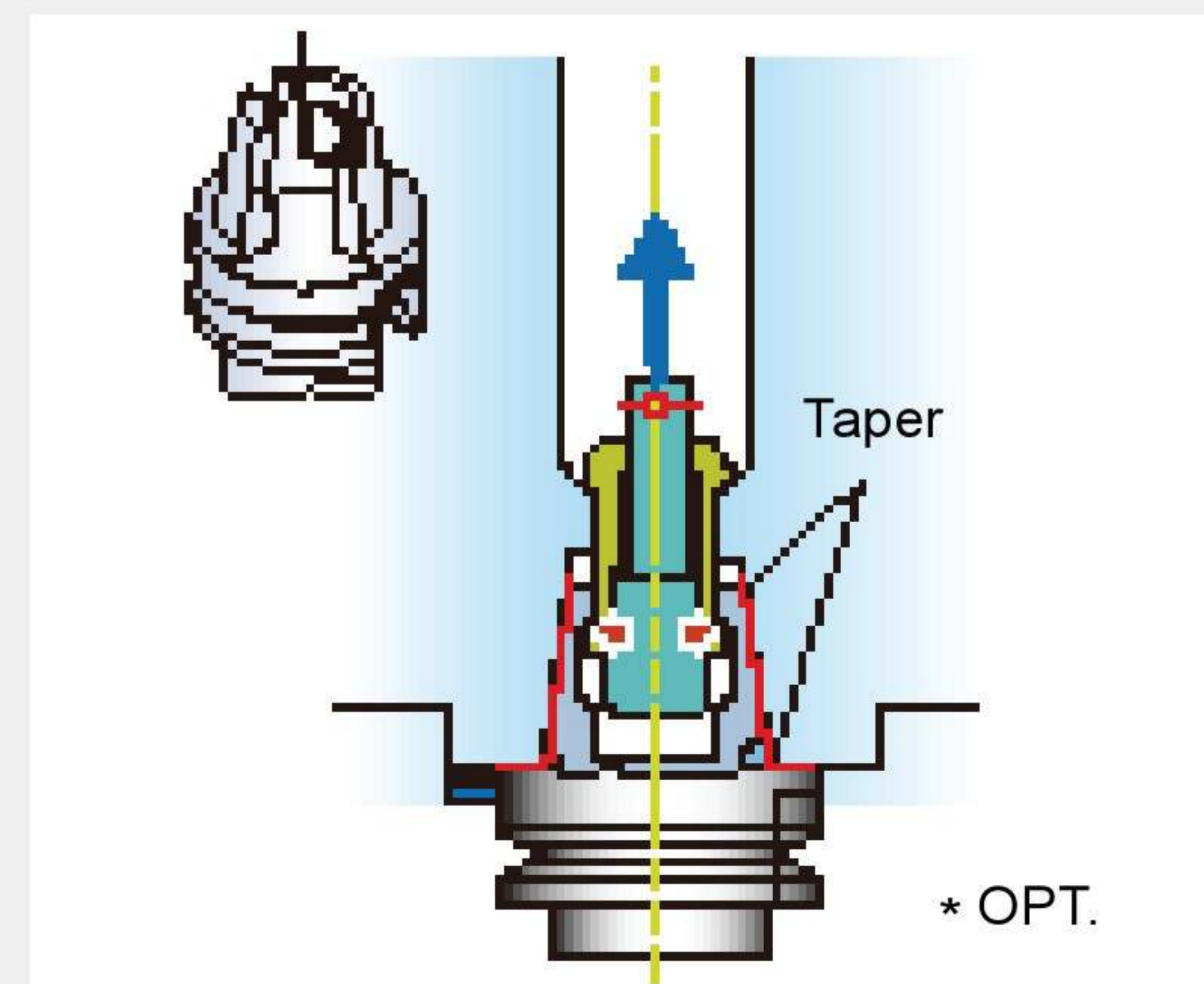
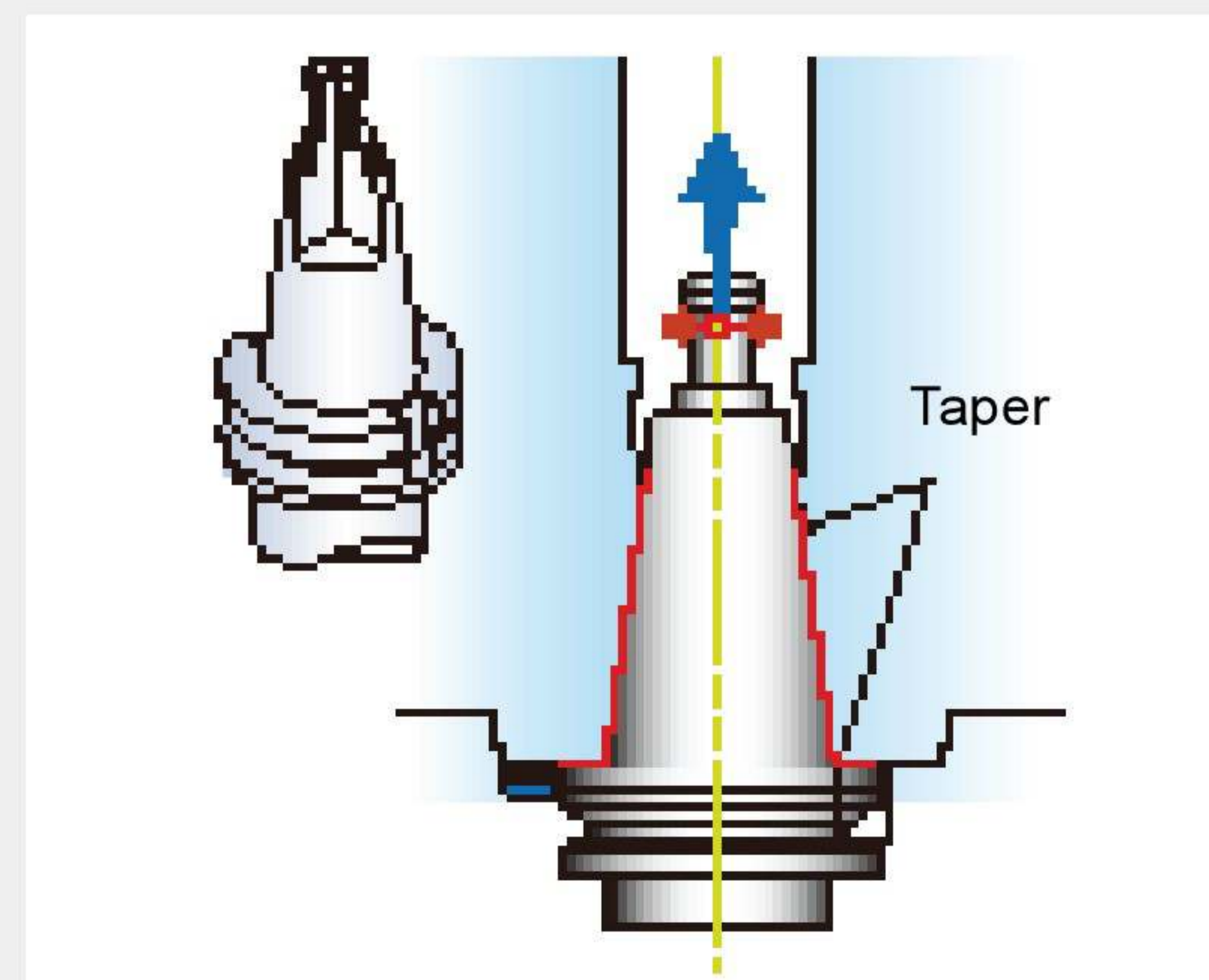

Rotary table (B-axis)

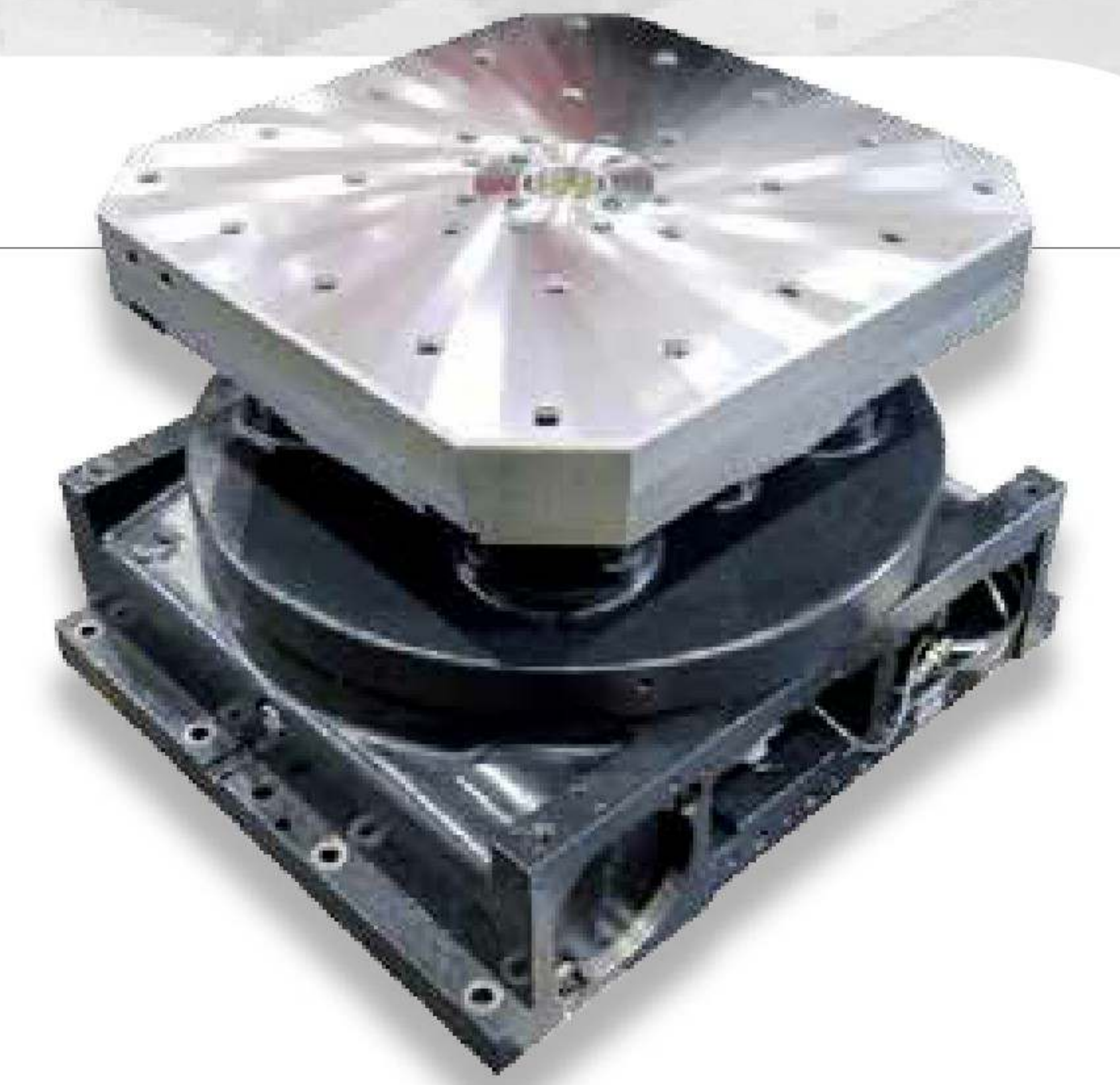

Machine is equipped with high-speed and high-precision will increase the machine work efficiency and reliability.

Type of rotary table	Standard	1° rotary table
Indexing	0.001°	1°

Chip removal system

▶ Chip flushing device, cooling device

Chip conveyor is located in the middle of the machine, which provides fast and smooth removal of chips from working and loading areas of machine.



Magazine



Tool Storage Capacity

Disk type

40 set 60 set OP

Chain type

120 set OP

This machine is installed with the high speed indexing and disk type magazines (40 tool specs) as standard. It comes up with the disk and chain type magazines for optional usage.

Max. Tool length

Prior model
HT-500
400mm



LNH-500
550mm

Max. tool weight

LNH-500
12kg

Max. tool diameter (no adjacent tool)

Prior model
HT-500
Ø160mm



LNH-500
Ø170mm

Tool changes per sec

LNH-500
4sec

Torque Curve

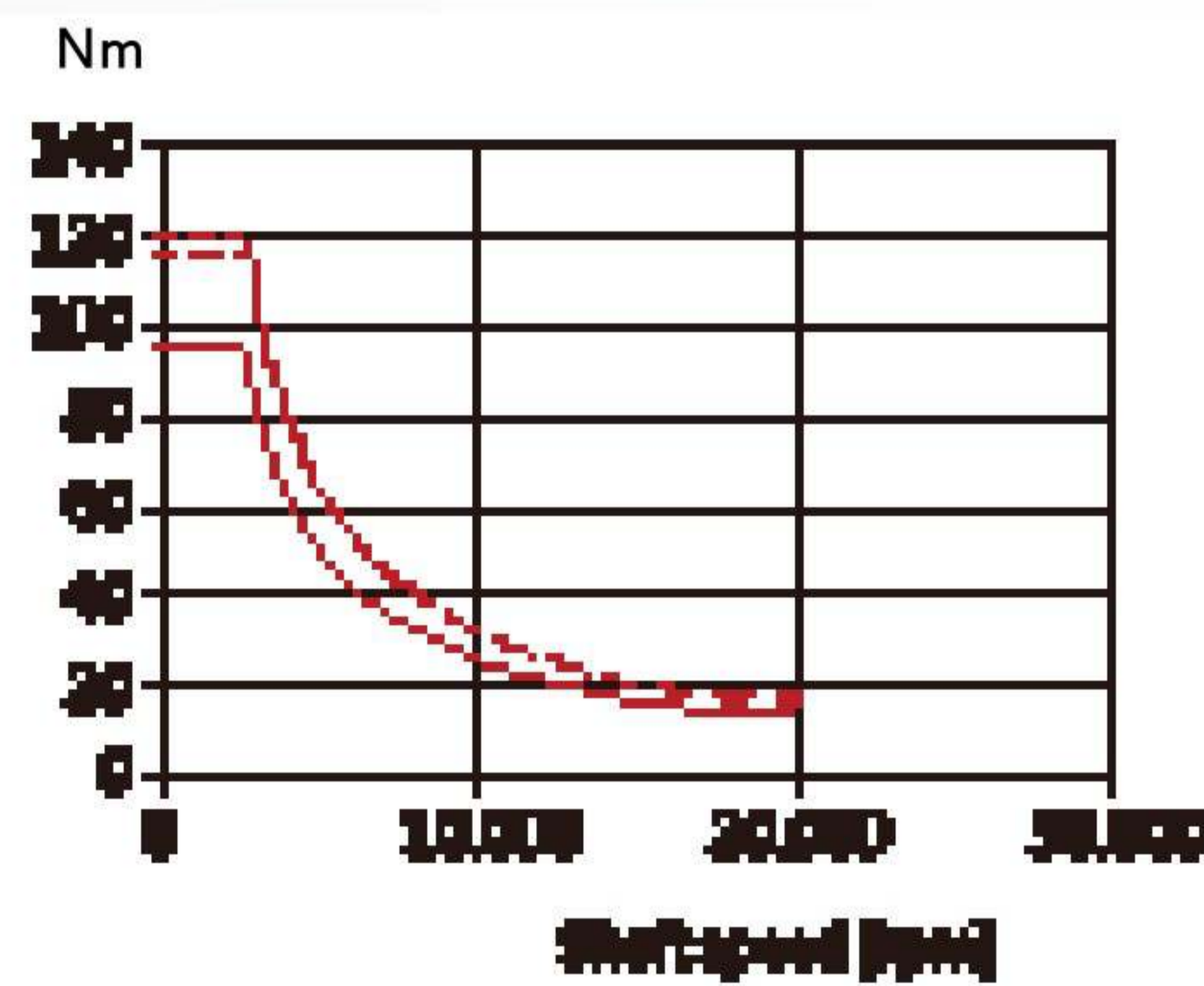
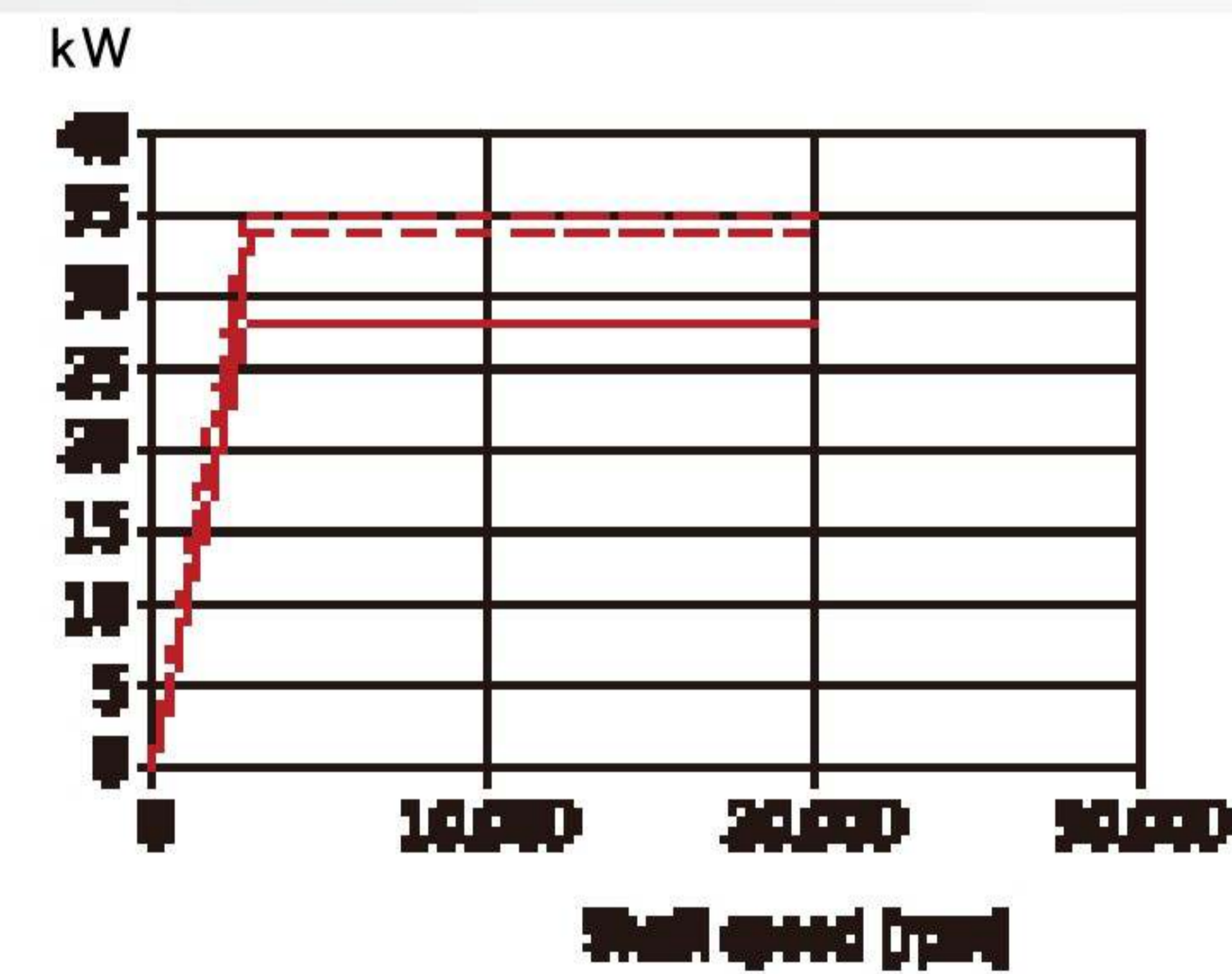

Floor Plan

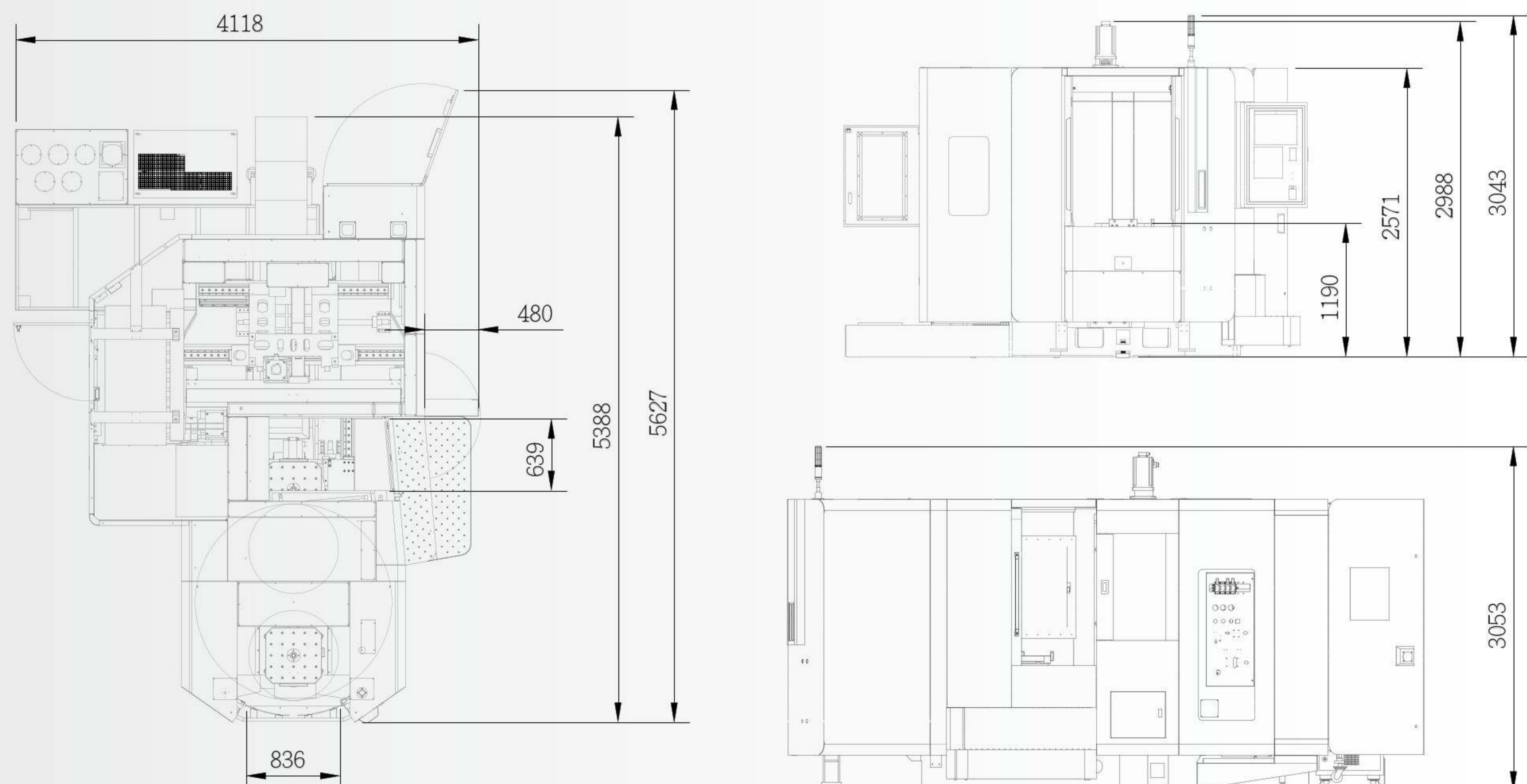

Unit : mm

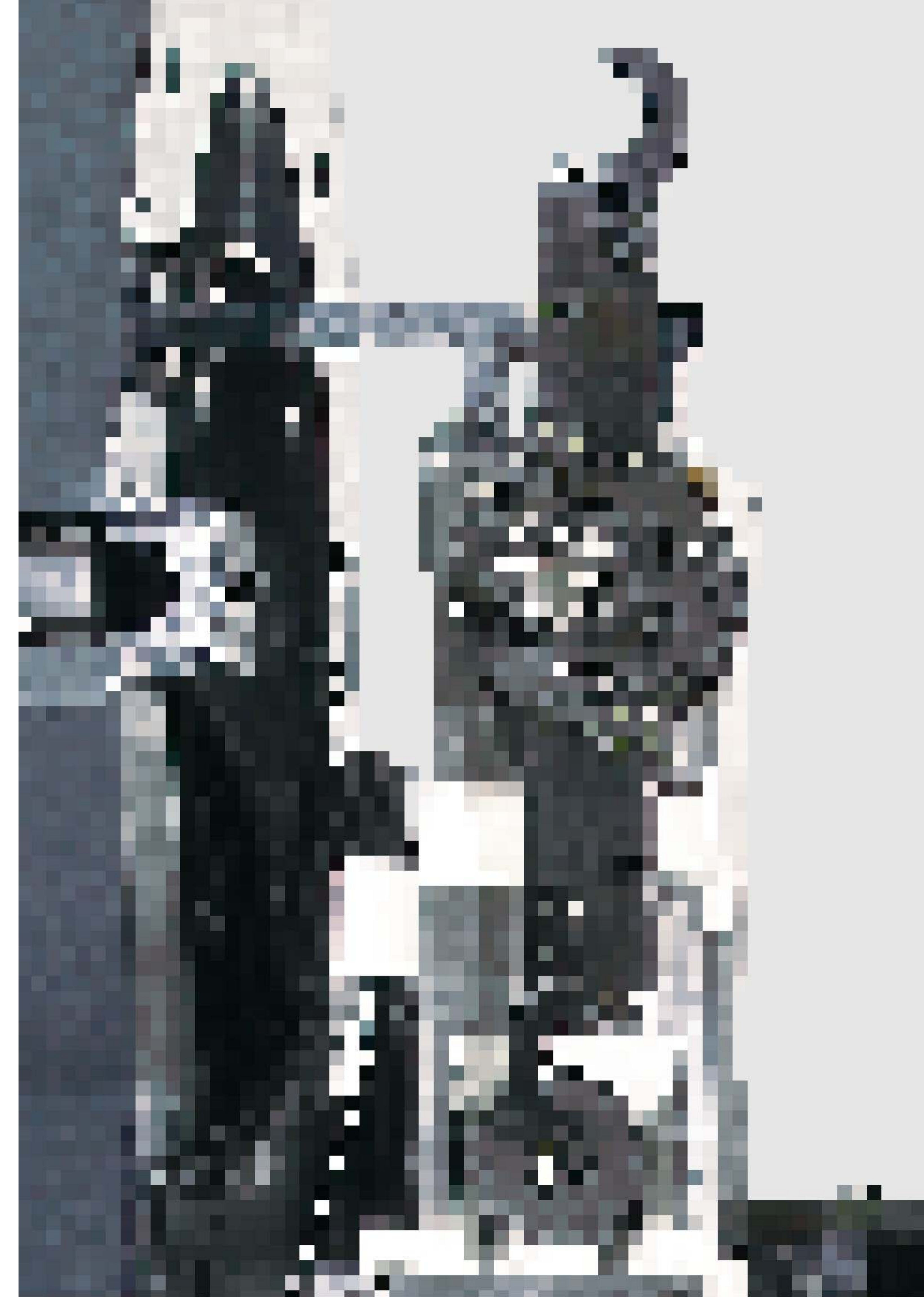

Automatic Tool Changer (ATC)

Reliable ATC Automatic Tool Change System

ATC cam mechanism adopts inverter drive to increase the reliability of tool change, support the multivariate variable speed adjustment and use by hold control rod fix tool, even much longer and heavier tool also can be fixed will and achieved reliable tool change.



Environment Protection

For the global environment, the main design of LNH-500 is environment protection.

- Oil Pressure and Frequency inverter (for energy saving) design
- Lubricating grease is used to achieve 'Environmental Performance'

Reduce power consumption 30%

The application of energy efficient motor system & power saving function reduce energy consumptions by 40%. Reduce cost effect obviously to meet the main design of environmental protection.

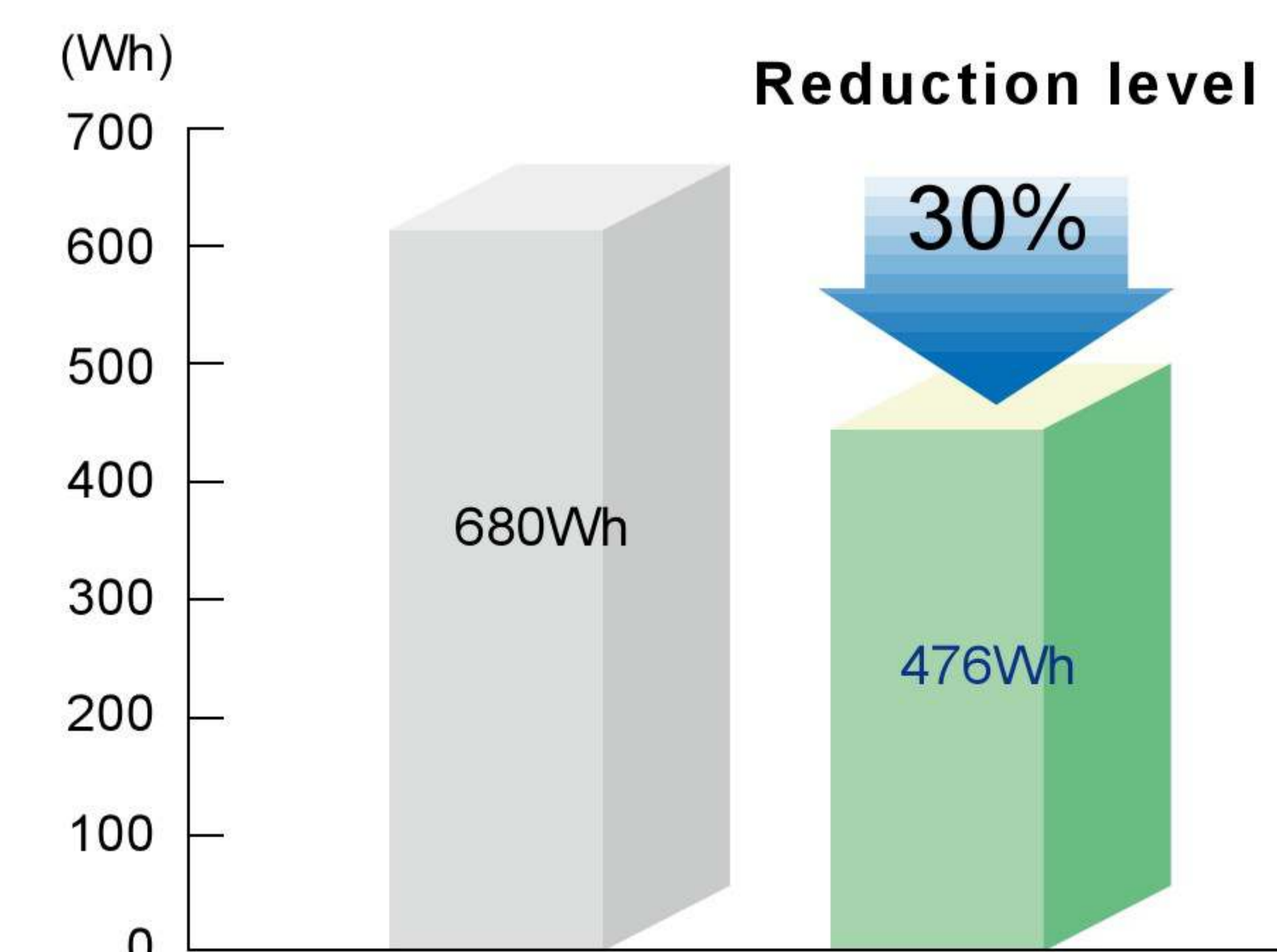

Reduce standby power consumption 57%

Power save operations of standby time is designed to minimize power consumption of machine's standby up to 57% for energy saving.

